

COMMERCIAL

LOWER A/C ENERGY COSTS BY UP TO 40%

**SUNTRAC
SOLAR**
AIR & HEAT

*We didn't invent solar A/C,
we perfected it.*

U.S. PATENT NUMBER #7665459



**INTEGRATES WITH YOUR
NEW EQUIPMENT
INSTALLATIONS, AND
EXISTING SYSTEM UPGRADES**

- Package/Split Units
- Mini/Multi Split Units
- Chiller Systems
- Energy Recovery Units
- Dehumidification Units
- Refrigeration Units

**COMPATIBLE WITH MOST
HIGH EFFICIENT HVAC
EQUIPMENT**

- Variable Speed
- Multi-Stage
- Variable Capacity



**SUNTRAC SMARTPANEL™
FEATURES**

- RiteTemp™ Temperature Control
- Scalable To Over 500 Tons
- Simple Installation
- 12v DC Power
- Self-contained Panel
- 5 Year Warranty



Copeland
brand products

KMC
CONTROLS

EMERSON
Climate Technologies

SUNTRAC SOLAR THERMAL SMARTPANEL

SUNTRAC
SOLAR
AIR & HEAT

*We didn't invent solar A/C,
we perfected it.*

FEATURES

- RiteTemp™ system eliminates stagnation conditions & controls high temperature limits
- Tracks daily east-to-west & returns to east at the end of day
- Designed for 25-year life
- Low voltage for safety
- Powder coated to resist harsh environments
- Removable glass top for easy access
- Tracking controller & brushless stepper motor are serviceable through motor cover
- Scalable for side-by-side mounting applications
- Tracking controller & brushless stepper motor are serviceable through motor cover

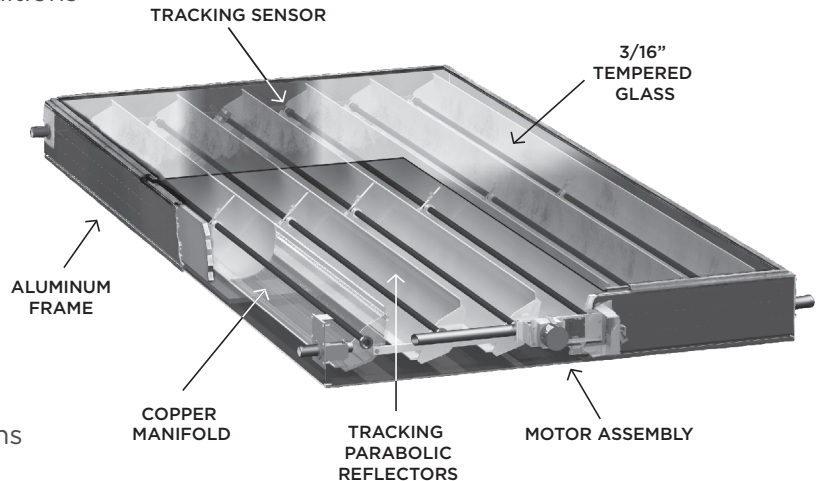

CONSTRUCTION & SPECIFICATIONS

Collector Case/Frame	Aluminum enclosure constructed from .063" 5052-H32 aluminum
Cover	Tempered plate glass, 3/16" thick (0.1875", 0.476 cm)
Cover Sealing	EPDM extruded U gasket, vulcanized corners
Insulation	0.5" (1.27 cm) thick insulation
Capacity	Up to 7.5 tons/90,000 BTU's/26 kW/40 hp of cooling & heating per collector
Net Aperture Area	Reflector area: 4' x 8' = 32 sq. ft.
Weight/Dimensions	190 pounds/86 kg, 96" x 48" x 7" (2.44m x 1.22m x 17.8cm)
Concentrators	Extruded aluminum parabolic reflector; Metalized aluminum foil mirror (for reflector surface); Teflon bearings for high temperatures and low friction
Absorber	Copper tubing: 5/8" ACR (12.7 cm), 1- 1/8" ACR (2.8575 cm) Black selective paint: absorptivity .92/.96, emissivity .2/.4
Sun Trackers	Two shaded phototransistors and brushless stepper motor Brushless stepper motor: 12vdc, 5W
Mounting Provisions	Recessed lip on frame for industry standard fasteners

SUNTRACSOLAR.COM / SALES +1 (480) 999-6091 EXT. 810